

**LIGHTFORCE gives you more light and innovative options for any driving conditions!**

Every LIGHTFORCE driving light comes supplied as standard with a clear spot beam polycarbonate cover. Polycarbonate is a Hi-tech material that is so strong it is used in fighter aircraft canopies and security screens due to its ability to withstand extreme impacts and stress.

**One set of LIGHTFORCE lights can do it all! LIGHTFORCE modular system saves you money!**

Below you can see our optional clip-on filters that enable you to tailor your driving lights in seconds to road conditions. These filters have been developed as a result of extensive and continuing research and development from all corners of the world. Why settle for the limitations of other brands?

SPOT (STANDARD)	COMBO	WIDE ANGLE
Every LIGHTFORCE driving light comes supplied with this clear cover. Offering unparalleled protection this cover allows maximum distance visibility and performance. Available in various colours to suit specific driving conditions.	All combo filters give a wide beam plus the bonus of a penetrating beam for increased visibility and driving safety. Not becoming the #1 choice of offroad racing and truck drivers worldwide!	These filters maximise the beam spread creating clear peripheral vision onto the side of the road and any hazards. The option of using one wide and one spot filter covers for varied road and terrain conditions.
SIZES: 140mm • 170mm • 240mm	SIZES: 170mm • 240mm	SIZES: 140mm • 170mm
<ul style="list-style-type: none"> <li>○ CRYSTAL CLEAR (Supplied as standard)</li> <li>● FOG YELLOW (Fog, haze, dust)</li> <li>● RUBY RED (Offroad/custom)</li> <li>● SAFETY AMBER (Offroad, haze, dust)</li> <li>● SNOW BLUE (Snow, sea spray, rain)</li> <li>● CRYSTAL BLUE (Increased clarity)</li> <li>● BLACK (Protective)</li> <li>● INFRA RED (Cover/security)</li> </ul>	<ul style="list-style-type: none"> <li>○ CRYSTAL CLEAR</li> <li>● FOG YELLOW (Fog, haze, dust)</li> <li>● SNOW BLUE (Snow, sea spray, rain)</li> <li>● CRYSTAL BLUE (Increased clarity)</li> <li>● SAFETY AMBER (Offroad, haze, dust)</li> </ul> <p><b>LEGAL:</b> Check your local laws regarding the use of coloured filters for regular on road use.</p>	<ul style="list-style-type: none"> <li>○ CRYSTAL CLEAR</li> <li>● FOG YELLOW (Fog, haze, dust)</li> <li>● CRYSTAL BLUE (Increased clarity)</li> </ul> <p><b>LEGAL:</b> Check your local laws regarding the use of coloured filters for regular on road use.</p>
		<p><b>FILTER TECH TIP:</b> To keep your LIGHTFORCE filters aligned straight in operation, just firmly bend the tabs to reposition filters onto reflector housing.</p> <p><b>WARNING:</b> DO NOT EVER attempt this with any other brand cover!</p>

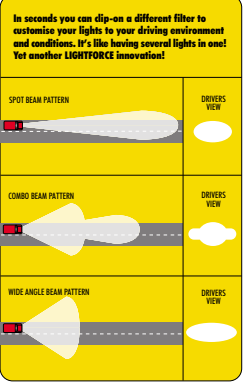

**LIGHTFORCE, legendary power!**

There is a myriad of aftermarket driving lights available to the consumer. In response to customers requesting comparison data between different models we formulated the following simple chart\*. As you can clearly see, the LIGHTFORCE models really measure up where it counts...LIGHT OUTPUT!

Many of our retailers attribute demand for LIGHTFORCE products due to customers witnessing the lights in use on the road. It's a combination of the quality of light as well as sheer light output on the road that sets LIGHTFORCE as a leader in auxiliary automotive lighting technology. SEEING IS BELIEVING!

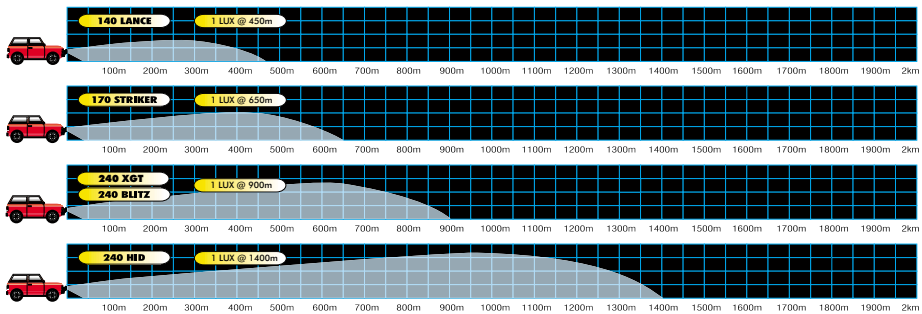

\*NOTE: The above diagrams are graphic representations only of comparative light output measured in distance of LIGHTFORCE driving light models. Actual distances achieved may differ due to different vehicle installations/wiring etc.

**LIGHTFORCE AUSTRALIA PTY LTD**

28 Orsmond Street  
Hindmarsh SA 5007  
AUSTRALIA  
TEL: (08) 8440 0888  
FAX: (08) 8346 0504

**INTERNATIONAL**  
TEL: + 61 8 8440 0888  
FAX: + 61 8 8346 0504

**LIGHTFORCE USA INC**

1040 Hazen Lane  
Oradino, IDAHO, 83544  
TEL: (208) 476-9814  
FAX: (208) 476-9817

LIGHTFORCE AUTHORISED DISTRIBUTOR



# VOTED BEST DRIVING LIGHT

Read the facts and **SEE** the light inside >



Welcome to **LIGHTFORCE** country...



**LIGHTFORCE wins 'MEGA SHOOTOUT'!**  
**Awarded 'BEST HALOGEN' & 'HID'!**

*In arguably the most comprehensive comparison of driving lights ever conducted, Australia's 4WD Monthly awarded LIGHTFORCE as the best halogen & HID light on the market today.*

*Against industry stalwarts, Hello, Cibie, KC, IPF, Narva and more... LIGHTFORCE was "... a cannon among pistols... and made others seem dim by comparison..."*  
 Read the full article @ [www.lightforce.com](http://www.lightforce.com)



RMDL240 'BLITZ'



professional performance

Whatever type of vehicle, the 240 BLITZ is perfect for those seeking extreme lighting performance on or offroad!

**Company Profile**

LIGHTFORCE is Australia's leading designer and manufacturer of an innovative range of portable high intensity modular lighting systems. Key design features that define LIGHTFORCE products result in lights that are stronger and lighter with optimal performance, exceeding that achieved by competitors.

LIGHTFORCE is committed to ongoing development of 'state of the art' spotlight technology and professional portable lighting solutions, utilising 'space age' injection moulded componentry. An example is the computer designed parabolic moulded reflectors. These are manufactured from extremely high temperature resistant engineering polymers, unique to LIGHTFORCE driving light and spotlight technology. The reflectors are metallised on the premises ensuring total quality control and unparallelled light output that has made LIGHTFORCE famous worldwide.

LIGHTFORCE lighting products have been in commercial production for more than fifteen years with the primary focus on product development and refinement. LIGHTFORCE driving lights are designed and constructed to offer clearly superior performance compared to outdated designs and inferior materials.

The products are designed and manufactured by our team of dedicated professionals at our facility located in Hindmarsh, South Australia. Our company distributes the LIGHTFORCE product portfolio throughout Australia and exports to many countries including the USA via our facility in Idaho.

Please contact your nearest LIGHTFORCE stockist with any queries you may have or feel free to contact us direct.

We trust you will find this catalogue informative and useful in choosing driving lights to enhance your vehicle and driving safety.

**IMPORTANT! Please read carefully!**

Check your local regulations regarding the use of auxiliary driving lights for regular road use.  
 LIGHTFORCE Australia / LIGHTFORCE USA and its dealers / representatives shall not be held responsible for any consequential liability as a result of the 'uses' non compliance with regional laws or government regulations.  
 Products and specifications detailed were correct at the time of publication but LIGHTFORCE Australia reserves the right to change these without notice. All images and contents depicted are property of LIGHTFORCE Australia and may not be published in any form (eg. press, video, internet) without prior written consent.  
 LIGHTFORCE Australia. All rights reserved • Jun 2004 ©.

**What is the light made of?**

A mixture of polycarbonate and glass filled nylon. These materials are extremely strong yet very light. LIGHTFORCE are acknowledged leaders in this technology.

**Why do we use these materials?**

Other lights on the market have glass lenses, with metal bodies. Some cheaper lights do have 'plastic' bodies but they still have glass lenses. Glass is heavy and breaks easily. Metal is also heavy, rusts and can fatigue. Our lights are usually significantly lighter than other brands yet with increased durability under extreme operational conditions.

**How do they go offroad?**

No problem! Because there is very little weight, rough roads and vibrations do not effect our lights. The more weight you have bouncing up and down on your protection bar or mounting point the more problems you are likely to encounter.

**What factors make LIGHTFORCE lights perform so well?**

**1: REFLECTOR QUALITY**

LIGHTFORCE reflectors are like a mirror. Compare our reflector quality against the opposition brands. Quite literally the heart of the legendary performance.

**2: REFLECTOR SHAPE**

Our reflectors are a near perfect parabola, many others compromise performance with overall cosmetic appearance.

**3: BULB QUALITY & NEW 'HID' XGD TECHNOLOGY**

The Xenophot® bulbs we use are of photographic quality and offer up to 20% increased brightness over conventional halogen types. They give a much whiter light than many automotive bulbs on the market, and are rated at up to 2000 hours at 12 volts.

Our 240 'HID' with xenon gas discharge technology, has won numerous awards including being awarded 'BEST HID' type driving light by Australia's 4WD Monthly magazine. For those seeking the #1 in power... look no further!

**The 240 'BLITZ' ... A legend!**

The 240 BLITZ very quickly attained a formidable reputation that literally blitzed all other lights on the market. The extreme long range beam allows increased visibility and driver safety. The ability to quickly customise the beam pattern in seconds with the virtually unbreakable clip-on filters adds to their value! One look and professionals worldwide agree that no other light comes close to these affordable lights in sheer power and overall performance.

**240 'BLITZ' features:**

- Variable beam patterns with optional clip-on filters
- Lightweight for less vibration
- Super strong polyamide hi-tech construction
- Hi-impact polycarbonate lens
- 12v 100 watt Xenophot® long life bulb
- 730 000 candlepower output (approx)
- Supplied with clear polycarbonate covers
- Optional 'combo' or coloured filters
- 24 volt option available

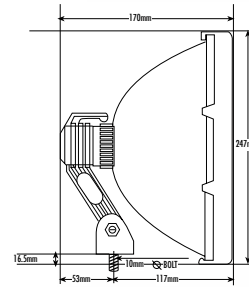

**LIGHTFORCE 12 volt driving light harness**

The LIGHTFORCE wiring harness assists in convenient installation and maximising performance from your LIGHTFORCE or any other driving lights. A quality wiring harness and installation is crucial to reliability and light output.

- Switch
- Resistor protected 30 amp relay
- Water proof blade fuse holder
- Extra long cables (for larger vehicles)
- All required terminals
- Comprehensive easy to understand instructions





## professional performance

Compact professional lighting POWER! The 'LANCE' and 'STRIKER' are ideal for any vehicle large or small!

### 140 'LANCE'

The compact 140 'LANCE' is ideal for installation on smaller vehicles. Despite its size the RMDL140 provides a very noticeable increase in visibility on the road, enhancing driver confidence and safety.

- Variable focus with optional clip-on filters
- Lightweight for less vibration
- Super strong polyamide hi-tech construction
- Hi-impact polycarbonate lens
- 12v 75 watt Xenophot® long life bulb (24v 50 watt avail.)
- 110 000 candlepower output (approx)
- Supplied with clear polycarbonate covers
- Optional wide angle clear filters
- Optional wide angle yellow filters
- Available in high or low mount (low depicted)

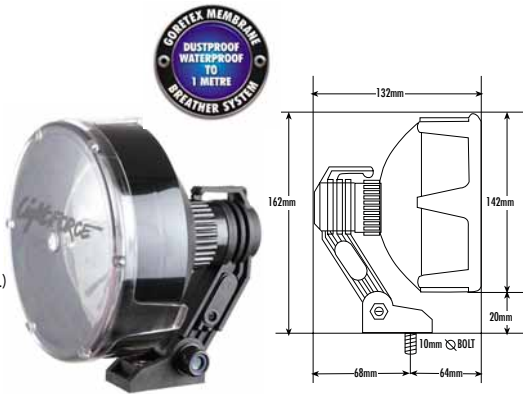

### 170 'STRIKER'

The midsize 'STRIKER' 170mm diameter light outperforms many larger competitors. It is a popular choice of many Australian 4WD enthusiasts and truck drivers.

- Variable focus with optional clip-on filters
- Lightweight for less vibration
- Super strong polyamide hi-tech construction
- Hi-impact polycarbonate lens
- 12v 100 watt Xenophot® long life bulb
- 350 000 candlepower output (approx)
- Supplied with clear polycarbonate covers
- Optional wide angle clear filters
- Optional wide angle yellow filters
- Optional wide/spot 'combo' filters
- Available in high or low mount (low depicted)
- 24 volt option available

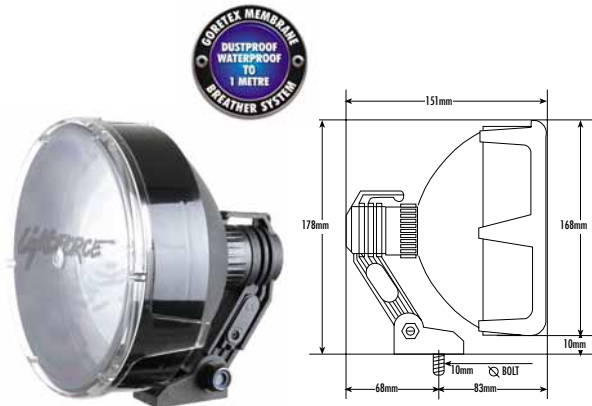

AWARDED BEST HALOGEN DRIVING LIGHT BY 4WD MONTHLY



### 240 XGT, The best value high performance driving light in the world!

Reflecting the spirit of the open road and long distances often traveled in Australia, LIGHTFORCE Australia have released the 240 'XGT' (XENON GRANDE TURISMO) driving light. LIGHTFORCE continues its tradition of building legendary performance into every light.

### Race bred heritage & performance!

Combining many of the award winning features of its legendary 240 'HID' model, the 'XGT' utilises a 12 volt 100 watt 2000 hour Xenophot® bulb offering up to 20% greater performance than a conventional halogen type bulb. The light housing and mounting system is race proven and has redefined optimum driving light design and materials. Additionally the shatterproof, clip on polycarbonate filters provide unrivaled versatility in customising the light for any driving conditions.

### Mount it any way you like!

Unlike many other lights on the market, the XGT can be mounted in any orientation, vertically, pendulum, or sideways and cope with any approach or departure angle in a water crossing scenario... try that with other lights!

### How tough? LIGHTFORCE has no equal!

Lightforce's strength is legendary! Under strict police supervision we subjected our lights to a test that redefines the concept of extreme testing! At a distance of 15 metres we subjected a light and filter cover to six rounds from a police issue 12 gauge Remington 870 pump action shotgun, utilising #7 shotshells. Result? The polycarbonate filters did not shatter like glass or acrylic. Unbelievably, the light was still shining bright! We invite any other manufacturer to try this test!

### Worldwide, drivers are making the change to LIGHTFORCE.

Drivers from the Arctic tundra to the extremes of the Australian outback look to LIGHTFORCE for innovation and performance in driving light technology. Gone are the days of old style, heavy weight metal and glass construction "Bull" lights.

### Quite simply, it's the 'VSP' factor!

Put simply, the XGT sets a new benchmark in ultra hi-performance driving lights, unmatched in versatility, strength and performance. LIGHTFORCE call this trend, the 'VSP' factor, VERSATILITY + STRENGTH + PERFORMANCE.



# professional performance

Rod Hall's 'TEAM HUMMER USA' debuting the 240 'HID' raced to a class victory in the infamous 2001 BAJA 1000!



**SUPERIOR DESIGN**

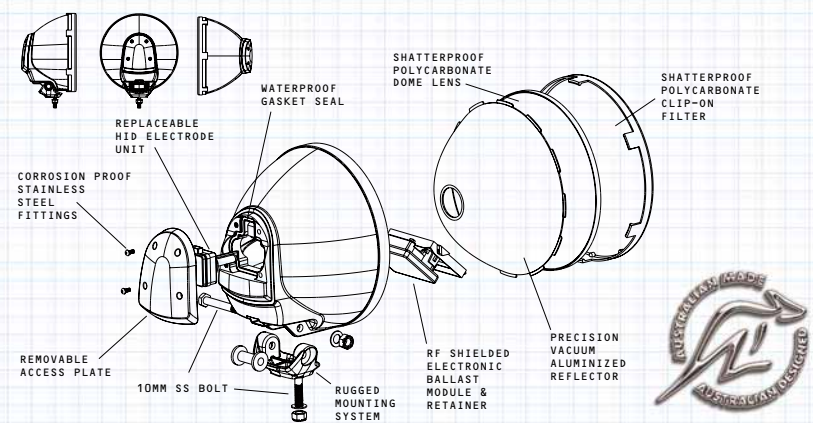

## The LIGHTFORCE 240 'HID' offers performance and features that simply has no equal in the world today!

The NEW 240 'HID' delivers UNMATCHED PERFORMANCE. Using xenon gas discharge 'HID' technology, it results in up to three times more light than the brightest 12v halogen bulb. Following a tradition for efficiency, this light draws approximately 3.00 amps, the equivalent draw of a 35 watt bulb! There is a lot more to a bright light than wattage! A full 35mm wider than the competition, the 225mm parabolic reflector offers you the most amplification available from a driving light. Shatterproof, polycarbonate hi-tech construction ensures rugged durability.

## Offroad race proven! To HELL and back!

Exhaustive field testing included Rod Hall's TEAM HUMMER USA winning their class at the infamous 2001 BAJA 1000 debuting the 240 'HID's. Offroad racing subjects driving lights to the most extreme conditions imaginable. Professional racers in the USA told us that most other lights continuously failed from the rigours typically encountered and were being replaced on a regular basis during a racing season. When many high profile professional teams tried LIGHTFORCE they were amazed at not only the 'brilliant' performance but the lights virtual indestructibility under race conditions. As a result they are rapidly being adopted as the light of informed choice and the teams have become an integral part of ongoing LIGHTFORCE research and development.

## Why the 240 'HID' is the ULTIMATE!

The whole unit weighs half that of its competitor! This is the toughest light we've ever made, and it's WATERPROOF! A breakthrough design makes the 240 'HID' easy to install. Unlike most other HID's, the LIGHTFORCE 240 'HID' has NO REMOTE BALLAST! The ballast is built into the light itself for better protection and easy installation making it the logical choice for those who refuse to compromise. The brightest, lightest, most durable, waterproof and easiest to install. This is quite simply the most advanced driving light ever made.

## Xenon discharge 'HID' technology

'HID' generates up to three times more light than the brightest 12v halogen bulb with an incredibly low draw of 3.00 amps, the equivalent draw of a 35 watt bulb.

## Safety & easy installation! The first integrated ballast in a driving light!

Unlike our competition, LIGHTFORCE incorporates the ballast controller into the light itself. The first of its kind in a purpose designed driving light configuration, this design makes installation easier, and all components are better protected from damage and greater user safety. Our competition requires remote installation of their ballasts, consuming more space on your vehicle and complicating the installation process.

## Arguably the most powerful driving light available in the world!

A computer designed parabolic reflector, measuring 225 mm in diameter offers you the most amplification available. This high performance vacuum aluminized coating and reflector shape is almost 20% wider than our competitors, enabling it to deliver unmatched illumination.

## Polyamide & polycarbonate construction

Incredibly robust and durable, weighing only 1.72 kg, half that of our closest competitor, our new 240 'HID' is corrosion and waterproof.

## Shatterproof lens & filter system

Proven not to shatter, even when shot by a 12 gauge shotgun with #7 shot at 15 metres and a .22 caliber rifle at 100 metres. Just take our word for it!

## Change beam pattern or colour in seconds using our clip-on filter system

The 240 'HID' uses the LIGHTFORCE versatile clip-on filter system. This allows you to change the colour of the beam for special applications and driving conditions. The beam pattern can be widened from the standard 2 degrees by fitting the supplied focusing kit comprising easy to install 6 and 12 degree focusing collars.

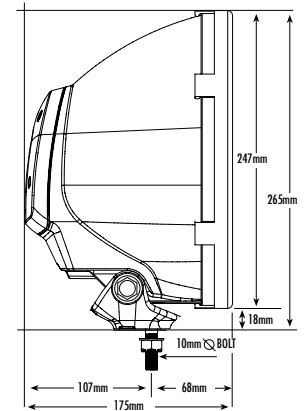

## Just plug in and light up! SIMPLE!

A power lead is supplied with a quality plug that just connects to your existing 12 volt system (24 volt model also avail.) Simply connect and plug it in and LIGHT UP! Compare that to other HID lights on the market! We even include a mounting kit with a modular spacer system to cater for any installation scenario.

## After the 2001 BAJA 1000, Team Hummer USA had this to say about the 240 'HID'...

*Portions of the course, often hazardous under normal conditions, proved barely negotiable for many race cars. LIGHTFORCE overcame freezing conditions, fog and dust to light TEAM HUMMER's way to victory. On one occasion, the rugged HID lights took a direct hit, colliding into hardy tree branches measuring four inches in diameter. Chad Hall and copilot Cort Stoskopf were sure the loud crack of the collision spelled doom for the new lights. Both were stunned when a flip of the toggle switch ignited the two HID's that performed flawlessly right to the finish line. Chad Hall concluded his critique with the remark, "I'll never race without them at night again!"*

## Award of merit

From the Design Institute of Australia, the 240 'HID' succeeded in being selected for an 'AWARD OF MERIT' for industrial design.



## Winner Australian 4WD Monthly 'PRODUCT OF THE YEAR' & BEST HID!

After exhaustive testing and rigorous scrutiny the LIGHTFORCE 240 'HID's were awarded the coveted prize in the 'BEST PRODUCT over \$500 category'.

Australia's 4WD Monthly subsequently compared the 240 'HID' against other competitors and awarded the LIGHTFORCE 240 'HID' as the best available on the market today. Quality and performance unsurpassed!



**"THE WORLD'S MOST ADVANCED DRIVING LIGHT"**  
240 HID XENON GAS DISCHARGE



**I-HID**  
XENON GAS DISCHARGE

